



BUILT TO LAST BUILT TO LAST BUILT TO LAST BUILT TO LAST BUILT TO LAST BUILT TO LAST

# Precision Mixers

BUILT TO LAST BUILT TO LAST BUILT TO LAST BUILT TO LAST BUILT TO LAST BUILT TO LAST

BUILT TO LAST BUILT TO LAST BUILT TO LAST BUILT TO LAST BUILT TO LAST BUILT TO LAST

## Standard Equipment Specifications



**Built to Last . . .  
Priced to Save!**

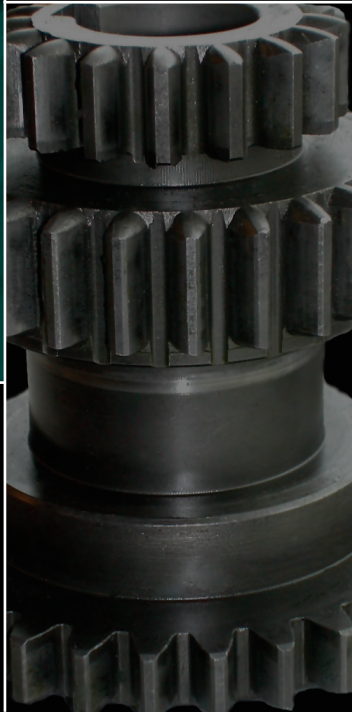
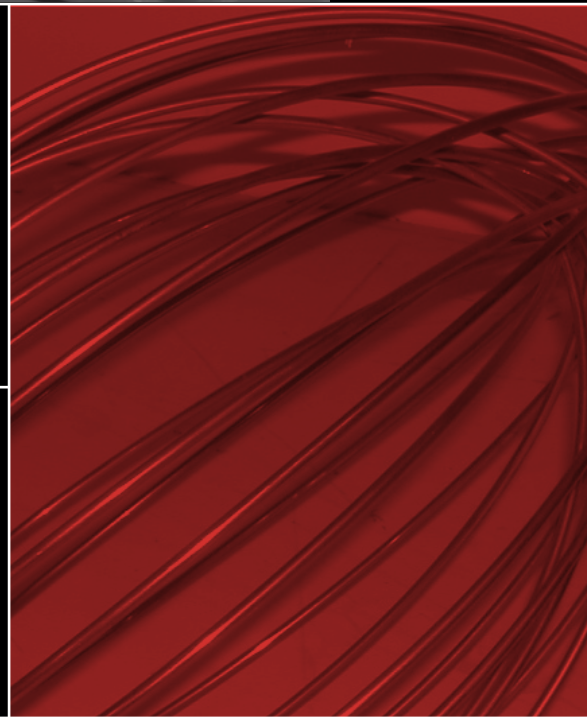

[www.precisionmixers.com](http://www.precisionmixers.com)

# Precision N. America LLC.

# Precision N. America LLC. Planetary Mixers



## Model Specifications

MODEL #	ITEM #	BOWL CAP	MOTOR HP.	VOLTS	PHASE
AV-01	AV-01	10 Quart	1/3	115	1
AV-02	AV-02	20 Quart	1/2	115	1
Hub-30	HUB-30	30 Quart	1	115	1
Hub-40	HUB-40	40 Quart	1 1/2	208/240	1
Hub-50	HUB-50	50 Quart	2	208/240	1
V-60	V-60.1	60 Quart	2	208/240	1
V-60	V-60.3	60 Quart	2	208/240	3
HD-60	HD-60.1	60 Quart	2	208/240	1
HD-60	HD-60.3	60 Quart	4	208/240	3
V-80	V-80.1	80 Quart	4	208/240	1
V-80	V-80.3	80 Quart	4	208/240	3
V-80EL	V-80.3EL	80 Quart	4 1/4	208/240	3
M-140W	M-140W	140 Quart	6 1/2	208/240	3

\*Specifications subject to change without notification



**Precision  
Mixers**

**Precision North America, LLC.**  
60 Commerce Ave.  
Albany, New York 12206

www.precisionmixers.com • Phone: 1-877-R-MIXERS (1-877-764-9377) • Fax: 518-462-3389

# Precision N. America LLC. Spiral Mixers

**S-80**



**S-100**



**S-150**



**S-200**



## Model Specifications

Model	Flour	Dough	Power	Phase	Volts
S-80	55 lbs.	88 lbs.	3.5 HP	3	208/240
S-100	84 lbs.	132 lbs.	4.75 HP	3	208/240
S-150	110 lbs.	176 lbs.	6.75 HP	3	208/240
S-200	165 lbs.	264 lbs.	7.5 & 3/4 HP	3	208/240
S-200B	165 lbs.	264 lbs.	10 & 2 HP	3	208/240

\*Specifications subject to change without notification



**Precision  
Mixers**

**Precision North America, LLC.**  
60 Commerce Ave.  
Albany, New York 12206

**www.precisionmixers.com • Phone: 1-877-R-MIXERS (1-877-764-9377) • Fax: 518-462-3389**



# WARRANTY

## ONE-YEAR PARTS & LABOR WARRANTY

Precision North America, LLC. warrants to the original purchaser of every new Precision Mixer and all parts thereof, to be free from defects in material and workmanship, under normal and proper use and maintenance service as specified by Precision N. America, LLC. and upon proper installation and start-up in accordance with the instruction packet supplied by each Precision mixer. Precision's obligation under this warranty is limited to a period of (1) year from the date of original installation, or 15 months after shipment date from Precision, whichever occurs first.

Any parts covered under this warranty that are determined by Precision N. America to have been defective within (1) one year of original installation or fifteen (15) months after shipment date from Precision N. America, whichever occurs first, is limited to the repair or replacement, including labor charges, of defective parts or assemblies. The labor warranty shall include standard straight time labor charges only, as determined by Precision N. America.

## ADDITIONAL 2 YEARS PART WARRANTY

In addition to the (1) one year warranty stated above, Precision N. America, LLC. includes an additional (2) two years warranty on the motor and complete drive train. Terms and conditions on the additional (2) two year parts warranty are the same as stated above, excluding labor.

## WARRANTY CLAIMS

All claims for labor or parts must be authorized through Precision North America, LLC. All claims should include: model number, serial number, proof of purchase, date of installation, and all pertinent information supporting the existence of the alleged defect.

## WHAT IS NOT COVERED BY THIS WARRANTY

Precision N. America's sole obligation under this warranty is limited to either repair or replacement of parts, subject to the additional limitations below. This warranty neither assumes nor authorizes any person to assume obligations other than those expressly covered by this warranty.

**NO CONSEQUENT DAMAGE.** PRECISION N. AMERICA, LLC. IS NOT RESPONSIBLE FOR ECONOMIC LOSS; OR SPECIAL, INDIRECT, OR CONSEQUENTIAL DAMAGES, INCLUDING WITHOUT LIMITATION, LOSSES OR DAMAGES ARISING FROM FOOD OR PRODUCT SPOILAGE CLAIMS WHETHER OR NOT ON ACCOUNT OF MACHINE MALFUNCTION.

**WARRANTY IS NOT TRANSFERABLE.** This warranty is not assignable and applies only in favor of the original purchaser/user to whom delivered. ANY SUCH ASSIGNMENT OR TRANSFER SHALL VOID THE WARRANTIES HEREIN MADE AND SHALL VOID ALL WARRANTIES, EXPRESS OR IMPLIED, INCLUDING ANY WARRANTY OF MERCHANTABILITY OR FITNESS FOR A PARTICULAR PURPOSE.

**IMPROPER USAGE.** PRECISION N. AMERICA, LLC. ASSUMES NO LIABILITY FOR THE PARTS OR LABOR COVERAGE FOR COMPONENT FAILURE OR OTHER DAMAGES RESULTING FROM IMPROPER USAGE OR INSTALLATION OR FAILURE TO CLEAN AND/OR MAINTAIN PRODUCT AS SET FORTH IN THE WARRANTY PACKET PROVIDED WITH THE MACHINE.

**ALTERATION, NEGLIGENCE, ABUSE, MISUSE, ACCIDENT, DAMAGE DURING TRANSIT, FIRE, FLOOD, ACTS OF GOD.** Precision N. America, LLC. is not responsible for the repair or replacement of any parts that Precision determines have been subjected after the date of manufacture to alteration, neglect, abuse, misuse, accident, damage during transit, fire, flood, or act of God.

**IMPROPER ELECTRICAL CONNECTIONS.** Precision N. America is Not RESPONSIBLE FOR THE REPAIR OR REPLACEMENT OF FAILED OR DAMAGED COMPONENTS RESULTING FROM ELECTRICAL POWER FAILURE, THE USE OF EXTENSION CORDS, LOW VOLTAGE, OR VOLTAGE DROPS TO THE MACHINE.

**NO IMPLIED WARRANTY OF MERCHANTABILITY OR FITNESS FOR A PARTICULAR PURPOSE.** THERE ARE NO OTHER WARRANTIES, EXPRESSED, IMPLIED OR STATUTORY, EXCEPT THE (1) YEAR LABOR & (3) THREE YEAR PARTS WARRANTY AS DESCRIBED ABOVE. THESE WARRANTIES ARE EXCLUSIVE AND IN LIEU OF ALL OTHER WARRANTIES, INCLUDING IMPLIED WARRANTY AND MERCHANTABILITY OR FITNESS FOR A PARTICULAR PURPOSE. THERE ARE NO WARRANTIES WHICH EXTEND BEYOND THE DESCRIPTION ON THE FACE HEREOF.

**OUTSIDE U.S.** This warranty does not apply to, and Precision N. America, LLC. is not responsible for, any warranty claims made on products sold or used outside the United States.

### WARRANTY Registration Card

**Precision N. America, LLC.  
Mail Card Immediately**

**This Card must be mailed  
immediately after installation  
date for warranty to be in effect.**

**Please Mail to:  
Precision North America, LLC.  
60 Commerce Ave.  
Albany, NY 12206**

Name \_\_\_\_\_ Mixer Model # \_\_\_\_\_ M/C # Machine Code \_\_\_\_\_

Type of Business \_\_\_\_\_ Business phone # \_\_\_\_\_

Address \_\_\_\_\_ City \_\_\_\_\_ State \_\_\_\_\_ Zip \_\_\_\_\_

Name of Power Company \_\_\_\_\_

This is to inform Precision N. America, Inc. that I, (owners name) \_\_\_\_\_

have had the above mixer installed in my place of business on (date) \_\_\_\_\_

The above warranties are in effect from this installation date, or 90 days after shipment from Precision,  
whichever comes first.

**Customer Signature** \_\_\_\_\_

Precision North America, LLC. phone: 518-462-3387 fax: 518-462-3389 www.precisionmixers.com

**IMPORTANT: Copy of sales receipt must accompany this warranty card for warranty to be valid**



## **Standard Equipment and Features**

- » Heavy Duty  $\frac{1}{3}$  Horse Power Motor
- » 115 Volt \*Must be on a dedicated Circuit\*
- » 8 Amps
- » Single Phase
- » 115/60/1
- » Gear-Driven Transmission
- » 3-Speed
- » Safety Bowl Guard
- » Bowl Lift Safety
- » Manual Bowl Lift
- » Dough Hook
- » Wire Whip
- » Beater/Paddle
- » Stainless Steel Bowl
- » Bowl Locking Handles
- » 7' Power Cord
- » Counter-Top Model
- » **Industry Leading 3-Year-Limited Parts Warranty**
- » **1-Year Full Parts and Labor Warranty**



**Built to Last . . .Priced to Save!**

**Precision North America, LLC.**  
**60 Commerce Ave.**  
**Albany, New York 12206**



**www.precisionmixers.com • Phone: 1-877-R-MIXERS (1-877-764-9377) • Fax: 518-462-3389**



### Specifications and Dimensions

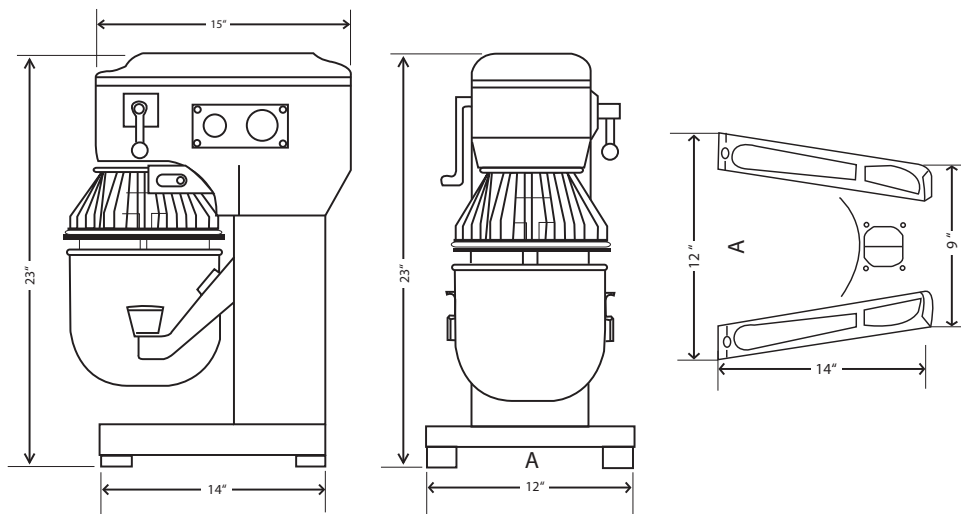

#### Electrical:

- 115Volt
- 1-Phase Power
- 220V, 1 or 3 phase available

#### Weight:

- 84 Pounds Net
- 95 Domestic shipping

#### Warranty:

- 3-Year Limited Parts, (Motor, Transmission, and Drive-Train).
- 1-Full Year Parts and Labor.

#### Amp Draw Specifications

Phase	Volts	Amps
1	115	8

#### Dimensions

##### Mixer Body:

- A: 12" Wide
- B: 23" High
- C: 15" Depth

##### Bowl:

- Outside w/handles: 13"
- Inside: 10½"
- Height: 9"

#### Benefits

##### Motor:

- Over-sized, Heavy-Duty, 1/3 Horse Power Motor
- Manual Reset Motor Overload

##### Bowl Locking Handles:

- Locks bowl in place

##### Power Supply:

- 7' Length Power Cord

**Easy Maintenance and Service  
National Network of Service  
Professionals**

#### Safety features

##### Bowl Guard:

- Auto shut-off when bowl guard is opened.

##### Lift Safety:

- Auto shut-off when bowl is lowered.

Speed	Agitator RPMs
1	76
2	142
3	259

Specifications are subject to change.

**Precision North America, LLC.**  
60 Commerce Ave.  
Albany, New York 12206



www.precisionmixers.com • Phone: 1-877-R-MIXERS (1-877-764-9377) • Fax: 518-462-3389



### Standard Equipment and Features

- » Heavy Duty ½ Horse Power Motor
- » 115 Volt \*Must be on a dedicated Circuit\*
- » 10.98 Amps
- » Single Phase
- » 115/60/1
- » Gear-Driven Transmission
- » 15-Minute Timer with automatic shut-off
- » 3-Speed
- » #12 Attachment Hub
- » Safety Bowl Guard
- » Bowl Lift Safety
- » Manual Bowl Lift
- » Dough Hook
- » Wire Whip
- » Beater/Paddle
- » Stainless Steel Bowl
- » Bowl Locking Handles
- » 7' Power Cord
- » Counter-Top Model
- » **Industry Leading 3-Year-Limited Parts Warranty**
- » **1-Year Full Parts and Labor Warranty**



**Built to Last . . .Priced to Save!**

**Precision North America, LLC.**  
**60 Commerce Ave.**  
**Albany, New York 12206**

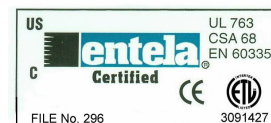

**www.precisionmixers.com • Phone: 1-877-R-MIXERS (1-877-764-9377) • Fax: 518-462-3389**



### Specifications and Dimensions

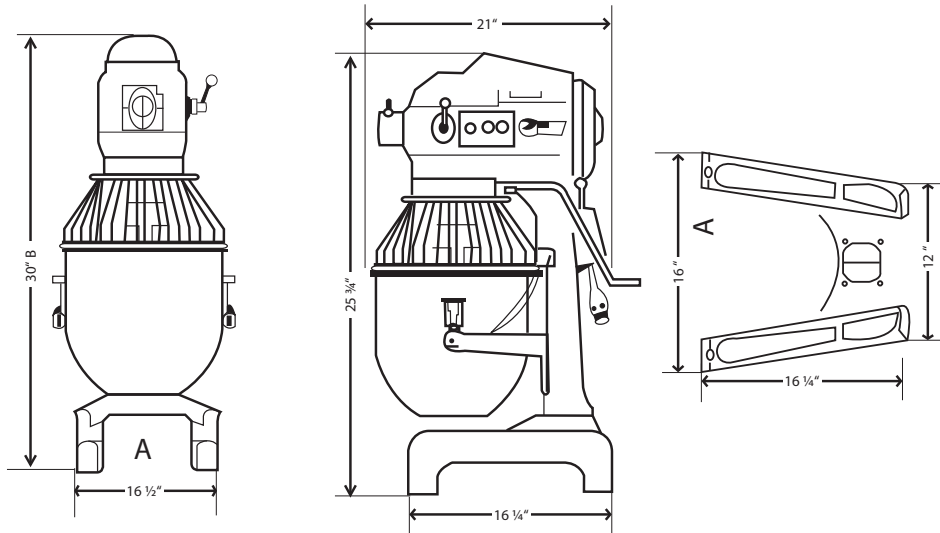

#### Electrical:

- 115Volt
- 1-Phase Power
- Entela Approved
- 220V, 1 or 3 phase available

#### Weight:

- 216 Pounds Net
- 256 Domestic shipping

#### Warranty:

- 3-Year Limited Parts, (Motor, Transmission, and Drive-Train).
- 1-Full Year Parts and Labor.

#### Amp Draw Specifications

Phase	Volts	Amps
1	115	10.98

#### Dimensions

##### Mixer Body:

- A: 16½" Wide
- B: 30" High
- C: 21" Depth

##### Bowl:

- Outside w/handles: 15½"
- Inside: 12<sup>5</sup>/<sub>8</sub>"
- Height: 11½"

**NOTE:** Hub attachment not to be used while mixing

#### Benefits

##### Motor:

- Over-sized, Heavy-Duty, ½ Horse Power Motor
- Manual Reset Motor Overload

##### Bowl Locking Handles:

- Locks bowl in place

##### Attachment Hub:

- Uses standard # 12 attachments

##### Power Supply:

- 7' Length Power Cord

##### Timer:

- Automatic shutoff at desired mixing time

**Easy Maintenance and Service**  
**National Network of Service Professionals**

#### Safety features

##### Bowl Guard:

- Auto shut-off when bowl guard is opened.

##### Lift Safety:

- Auto shut-off when bowl is lowered.

Speed	Agitator RPMs	Attachment Hub RPM's
1	76	125
2	142	248
3	259	453

Specifications are subject to change.

**Precision North America, LLC.**  
**60 Commerce Ave.**  
**Albany, New York 12206**



**www.precisionmixers.com • Phone: 1-877-R-MIXERS (1-877-764-9377) • Fax: 518-462-3389**





## Standard Equipment and Features

- » 1 Horse Power Motor
- » 115 Volt \*Must be on a dedicated Circuit\*
- » 12.67 Amps draw
- » Single Phase
- » 115/60/1
- » Gear-Driven Transmission
- » 30-Minute Timer with automatic shut-off
- » 3-Speed
- » #12 Attachment Hub
- » Safety Bowl Guard
- » Bowl Lift Safety
- » Dough Hook
- » Wire Whip
- » Beater/Paddle
- » Stainless Steel Bowl
- » Bowl Locking Handles
- » Bowl Stabilizer
- » **Industry Leading 3-Year-Limited Parts Warranty**
- » **1-Year Full Parts and Labor Warranty**



**Built to Last . . . Priced to Save!**

**Precision North America, LLC.**  
**60 Commerce Ave.**  
**Albany, New York 12206**



**www.precisionmixers.com • Phone: 1-877-R-MIXERS (1-877-764-9377) • Fax: 518-462-3389**



### Specifications and Dimensions

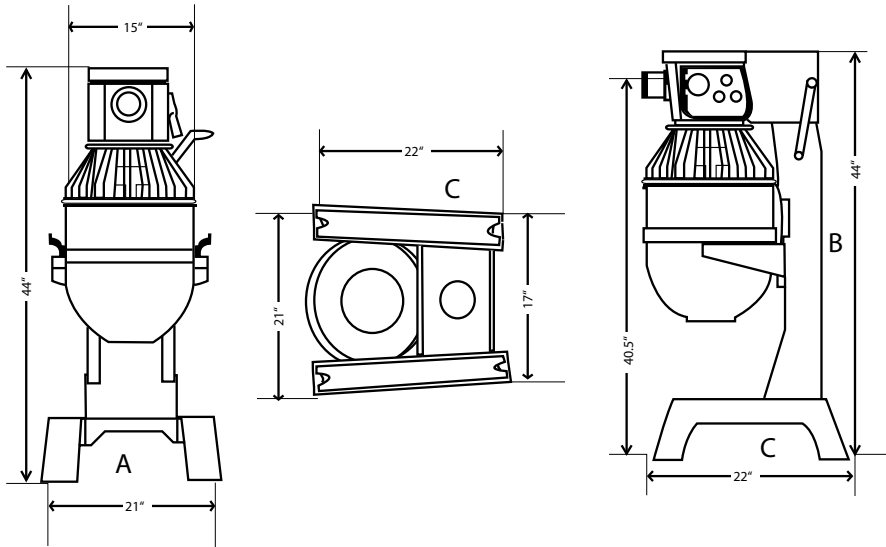

#### Electrical:

- 115Volt
- 1-Phase Power
- Entela Approved
- 220V, 1 or 3 phase available

#### Weight:

- 352 Pounds Net
- 427 Domestic shipping

#### Warranty:

- 3-Year Limited Parts, (Motor, Transmission, and Drive-Train).
- 1-Full Year Parts and Labor.

#### Amp Draw Specifications

Phase	Volts	Amps
1	115	12.67

#### Dimensions

##### Mixer Body:

- A: 21" Wide
- B: 44" High
- C: 22" Length

##### Bowl:

- Outside w/handles: 18½"
- Inside: 14½"
- Height: 15½"

**NOTE:** Hub attachment not to be used while mixing

#### Benefits

##### Motor:

- Heavy-Duty, 1 Horse Power Motor
- Manual Reset Motor Overload

##### Bowl Stabilizer:

- Flat Exterior Bowl Base for Bowl Stability

##### Attachment Hub:

- Uses standard # 12 attachments

##### Power Supply:

- 6' Length Power Cord

##### Timer:

- Automatic shutoff at desired mixing time

**Easy Maintenance and Service**  
**National Network of Service Professionals**

#### Safety features

##### Bowl Guard:

- Auto shut-off when bowl guard is opened.

##### Lift Safety:

- Auto shut-off when bowl is lowered.

Speed	Agitator RPMs	Attachment Hub RPM's
1	78	136
2	140	245
3	250	437

Specifications are subject to change.

**Precision North America, LLC.**  
**60 Commerce Ave.**  
**Albany, New York 12206**



**www.precisionmixers.com • Phone: 1-877-R-MIXERS (1-877-764-9377) • Fax: 518-462-3389**



## Standard Equipment and Features

- » 1-½ Horse Power Motor
- » 208/240 Volt
- » 10 Amp draw
- » Single Phase
- » Gear-Driven Transmission
- » 30-Minute Timer with automatic shut-off
- » 3-Speed
- » #12 Attachment Hub
- » Safety Bowl Guard
- » Bowl Lift Safety
- » Dough Hook
- » Wire Whip
- » Beater/Paddle
- » Stainless Steel Bowl
- » Bowl Locking Handles
- » Bowl Stabilizer
- » **Industry Leading 3-Year-Limited Parts Warranty**
- » **1-Year Full Parts and Labor Warranty**

## Optional Accessories

- » 20-quart Knockdown Plate
- » 20-quart Bowl
- » Whip, Beater, and Hook for 20-quart Bowl

**Please specify when ordering mixer.**



## Built to Last . . . Priced to Save!

**Precision North America, LLC.**  
**60 Commerce Ave.**  
**Albany, New York 12206**



**www.precisionmixers.com • Phone: 1-877-R-MIXERS (1-877-764-9377) • Fax: 518-462-3389**



### Specifications and Dimensions

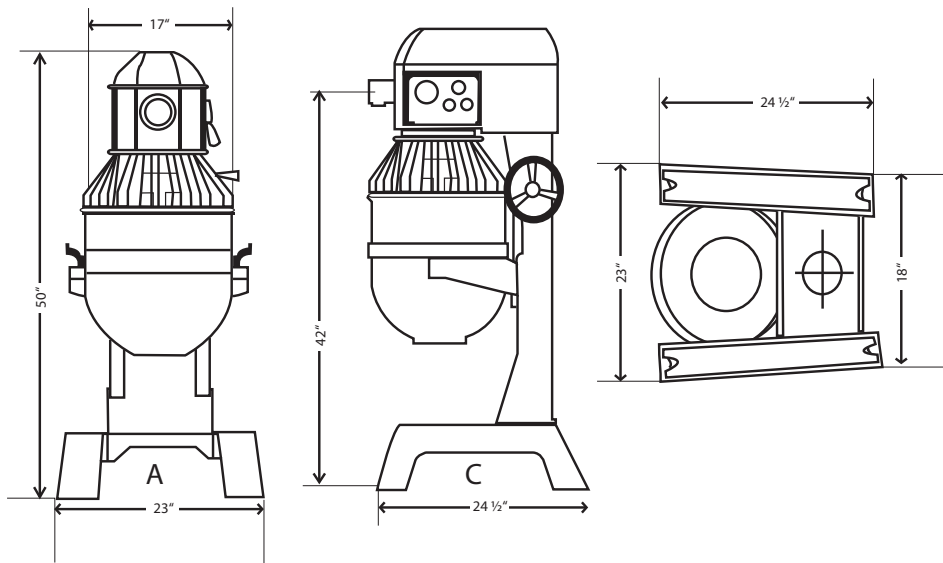

#### Electrical:

- 208/240 Volt
- 1-Phase Power
- Entela Approved

#### Weight:

- 462 Pounds Net
- 562 Domestic shipping

#### Warranty:

- 3-Year Limited Parts, (Motor, Transmission, and Drive-Train).
- 1-Full Year Parts and Labor.

#### Amp Draw Specifications

Phase	Volts	Amps
1	208/240	10

#### Dimensions

##### Mixer Body:

- A: 23" Wide
- B: 50" High
- C: 24 1/2" Depth

##### Bowl:

- Outside w/handles: 21 1/2"
- Inside: 15 3/8"
- Height: 16 1/4"

**NOTE:** Hub attachment not to be used while mixing

#### Benefits

##### Motor:

- Heavy-Duty, 1 1/2 Horse Power Motor
- Manual Reset Motor Overload

##### Bowl Lift:

- Locks in any position

##### Bowl Stabilizer:

- Flat Exterior Bowl Base for Bowl Stability

##### Attachment Hub:

- Uses standard # 12 attachments

##### Power Supply:

- 7' Length Power Cord

##### Timer:

- Automatic shutoff at desired mixing time

**Easy Maintenance and Service  
National Network of Service  
Professionals**

#### Safety features

##### Bowl Guard:

- Auto shut-off when bowl guard is opened.

##### Lift Safety:

- Auto shut-off when bowl is lowered.

Speed	Agitator RPMs	Attachment Hub RPM's
1	55	96
2	105	183
3	230	402

Specifications are subject to change.

**Precision North America, LLC.**  
60 Commerce Ave.  
Albany, New York 12206

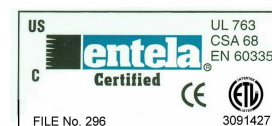

www.precisionmixers.com • Phone: 1-877-R-MIXERS (1-877-764-9377) • Fax: 518-462-3389



## Standard Equipment and Features

- » 2 Horse Power Motor
- » 208/240 Volt
- » 12.60 Amps draw
- » Single Phase
- » 208/60/1
- » Gear-Driven Transmission
- » 30-Minute Timer with automatic shut-off
- » 3-Speed
- » #12 Attachment Hub
- » Safety Bowl Guard
- » Bowl Lift Guard
- » Dough Hook
- » Wire Whip
- » Beater/Paddle
- » Stainless Steel Bowl
- » Bowl Locking Handles
- » Bowl Stabilizer
- » **Industry Leading 3-Year-Limited Parts Warranty**
- » **1-Year Full Parts and Labor Warranty**



**Built to Last . . . Priced to Save!**

**Precision North America, LLC.**  
**60 Commerce Ave.**  
**Albany, New York 12206**



**www.precisionmixers.com • Phone: 1-877-R-MIXERS (1-877-764-9377) • Fax: 518-462-3389**



### Specifications and Dimensions

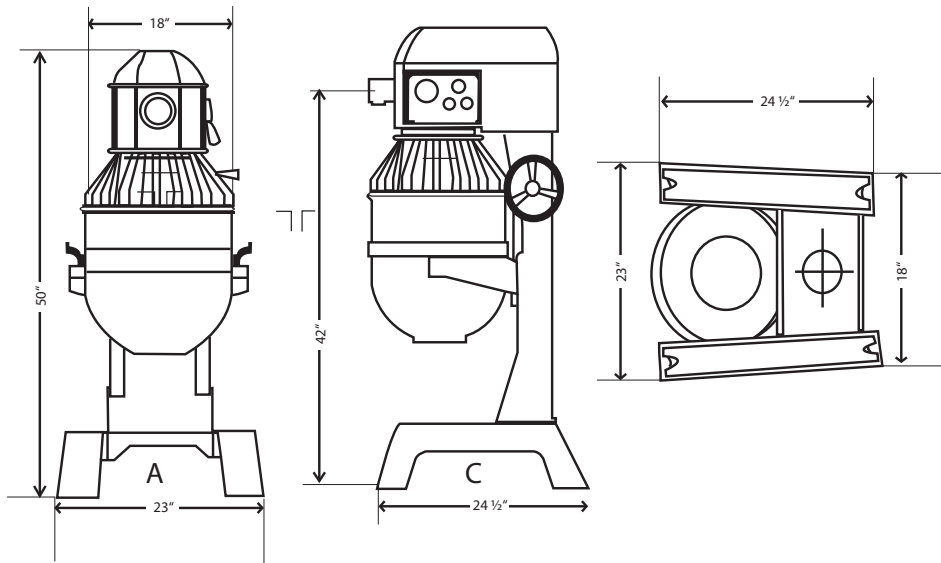

#### Electrical:

- 208/240Volt
- 1-Phase Power
- Entela Approved

#### Weight:

- 482 Pounds Net
- 584 Domestic shipping

#### Warranty:

- 3-Year Limited Parts, (Motor, Transmission, and Drive-Train).
- 1-Full Year Parts and Labor.

#### Amp Draw Specifications

Phase	Volts	Amps
1	208	14.5
1	230	12.6

#### Dimensions

##### Mixer Body:

- A: 23" Wide
- B: 50" High
- C: 24½" Depth

##### Bowl:

- Outside w/handles: 21½"
- Inside: 16<sup>3</sup>/<sub>8</sub>"
- Height: 17¼"

**NOTE:** Hub attachment not to be used while mixing

#### Benefits

##### Motor:

- Heavy-Duty, 2-Horse Power Motor
- Manual Reset Motor Overload

##### Bowl Lift:

- Locks in any position

##### Bowl Stabilizer:

- Flat Exterior Bowl Base for Bowl Stability

##### Attachment Hub:

- Uses standard # 12 attachments

##### Power Supply:

- 6' Length Power Cord

##### Timer:

- Automatic shutoff at desired mixing time

**Easy Maintenance and Service  
National Network of Service Professionals**

#### Safety features

##### Bowl Guard:

- Auto shut-off when bowl guard is opened.

##### Lift Safety:

- Auto shut-off when bowl is lowered.

Speed	Agitator RPMs	Attachment Hub RPM's
1	55	96
2	105	183
3	230	402

Specifications are subject to change.

**Precision North America, LLC.**  
60 Commerce Ave.  
Albany, New York 12206

www.precisionmixers.com • Phone: 1-877-R-MIXERS (1-877-764-9377) • Fax: 518-462-3389





**Precision  
Mixers**

**Precision 60-Quart Mixer**

**Model HD-60**

## Designed Exclusively for Pizzerias

### Standard Equipment and Features

- » 208/240 Volt
- » Single or 3-Phase
- » Gear-Reduction Transmission
- » 30-Minute Timer with automatic shut-off
- » 3-Speed
- » #12 Attachment Hub
- » Stainless Steel Bowl Guard
- » Bowl Lift Safety
- » Manual Bowl Lift
- » Dough Hook
- » Beater/Paddle
- » 80-quart Stainless Steel Bowl
- » Bowl Dolly
- » Bowl Locking Handles
- » Bowl Stabilizer
- » **Industry Leading 7-Year Unconditional Warranty on All Gears & Shafts in the Planetary & Transmission**
- » **Also, Our Standard 1-Year / 3-Year Warranty**



### Optional Accessories

- » 40-quart Knockdown Plate
- » 40-quart Bowl
- » 40-quart Paddle, Hook, and whip
- » Electric Bowl Lift
- » 60-quart bowl

Please specify when ordering mixer.

**The Perfect Pizza Machine  
at the perfect price!**

**[www.pizzamixers.com](http://www.pizzamixers.com)**

**Precision North America, LLC.**  
**60 Commerce Ave.**  
**Albany, New York 12206**



**www.precisionmixers.com • Phone: 1-877-R-MIXERS (1-877-764-9377) • Fax: 518-462-3389**



### Specifications and Dimensions

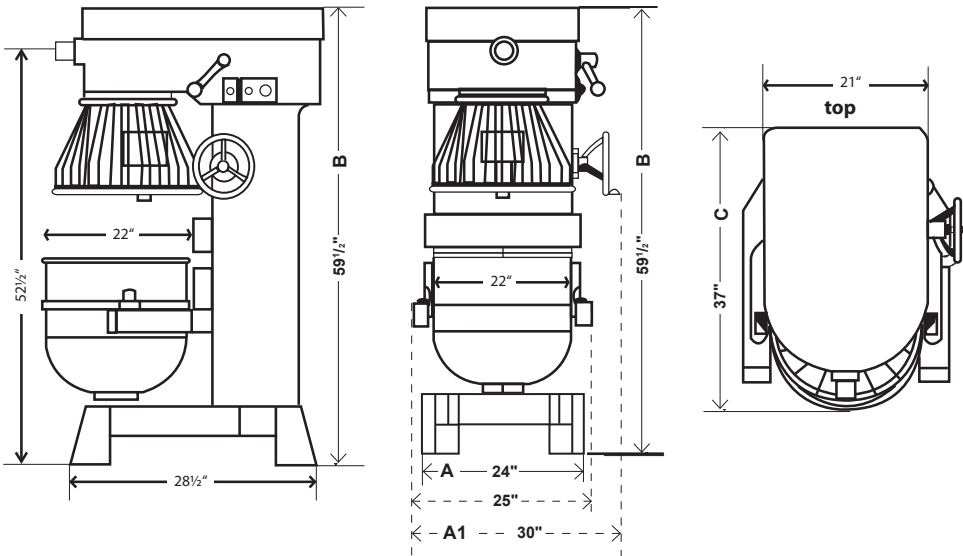

#### Electrical:

- 208/240 Volt
- 1 or 3-Phase Power
- Entela Approved

#### Weight:

- 880 Pounds Net
- 1005 Domestic Shipping

#### Warranty:

- 3-Year Limited Parts, (Motor, Transmission, and Drive-Train)
- 1-Full Year Parts and Labor

#### Amp Draw Specifications

Phase	Volts	Amps
1	208	17
1	240	15
3	208	16.1
3	240	14

#### Dimensions

##### Mixer Body:

A: 24" Wide A1: 30" Wide

B: 59 1/2" Wide

C: 37" Wide

##### Bowl:

Outside w/handles: 25"

Inside: 19 14/16"

Height: 19 1/2"

Lip: 21 1/2"

#### Benefits

##### Motor:

- 4-Horse Power, 3-Phase
- 2-Horse Power, Single Phase
- Manual Reset Motor Overload

##### Bowl Lift:

- Locks in any position

##### Bowl Stabilizer:

- Flat Exterior Bowl Base for Bowl Stability

##### Attachment Hub:

- Uses standard # 12 attachments

##### Timer:

- Automatic shutoff at desired mixing time

**Easy Maintenance and Service  
National Network of Service  
Professionals**

#### Safety features

##### Bowl Guard:

- Auto shut-off when bowl guard is opened.

##### Lift Safety:

- Auto shut-off when bowl is lowered.

Speed	Agitator RPMs	Attachment Hub RPM's
1	65	74
2	124	142
3	208	239

Specifications are subject to change.

**NOTE: Hub attachment not to be used while mixing**

**Precision North America, LLC.  
60 Commerce Ave.  
Albany, New York 12206**

**www.precisionmixers.com • Phone: 1-877-R-MIXERS (1-877-764-9377) • Fax: 518-462-3389**







**Precision  
Mixers**

## Precision 60-Quart Mixer

**Model V-60**

### Standard Equipment and Features

- » 2 - Horse Power Motor
- » 208/230 Volt
- » Single or 3-Phase
- » Gear-Reduction Transmission
- » 30-Minute Timer with automatic shut-off
- » 3-Speed
- » #12 Attachment Hub
- » Stainless Steel Bowl Guard
- » Manual Bowl Lift
- » Bowl Lift Safety
- » Dough Hook
- » Wire Whip
- » Beater/Paddle
- » Stainless Steel Bowl
- » Bowl Locking Handles
- » Bowl Stabilizer
- » **Industry Leading, 3-Year Limited Parts Warranty**
- » **1-Year Full Parts and Labor Warranty**

### Optional Accessories

- » 40-quart Bowl
- » Whip, Beater, and Hook for 40-quart Bowl

**Please specify when ordering mixer.**



## Built to Last . . . Priced to Save!

**Precision North America, LLC.**  
**60 Commerce Ave.**  
**Albany, New York 12206**



**www.precisionmixers.com • Phone: 1-877-R-MIXERS (1-877-764-9377) • Fax: 518-462-3389**



### Specifications and Dimensions

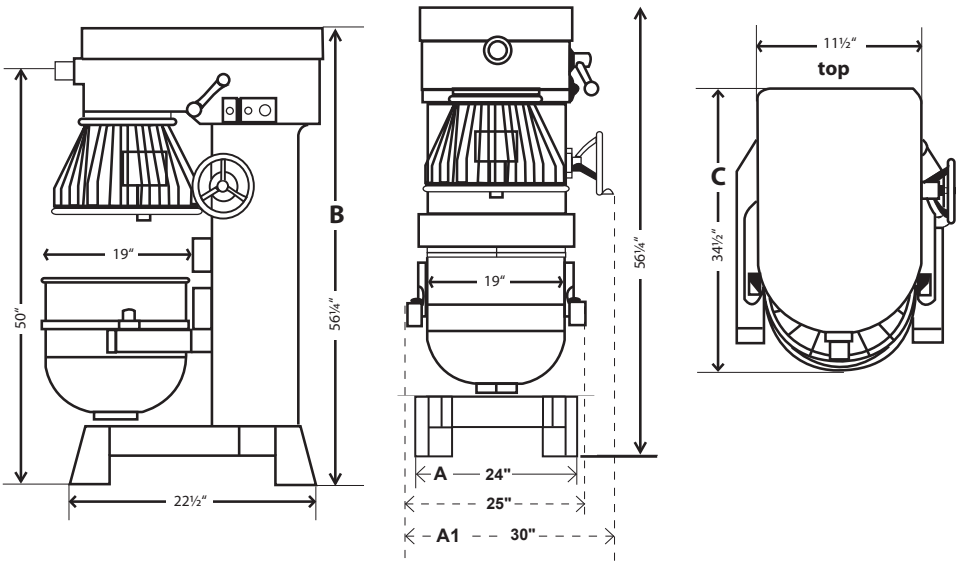

#### Electrical:

- 208/240 Volt
- 1 or 3-Phase Power
- Entela Approved

#### Weight:

- 814 Pounds Net
- 940 Domestic Shipping

#### Warranty:

- 3-Year Limited Parts, (Motor, Transmission, and Drive-Train)
- 1-Full Year Parts and Labor

#### Amp Draw Specifications

Phase	Volts	Amps
1	208	16.9
1	240	14.7
3	208	7.5
3	240	6.5

#### Dimensions

##### Mixer Body:

A: 24" Wide A1: 30" Wide

B: 59 1/2" High

C: 37" Depth

##### Bowl:

Outside w/handles: 25"

Inside: 18 1/2"

Height: 18 1/4"

**NOTE:** Hub attachment not to be used while mixing

#### Benefits

##### Motor:

- Heavy Duty, 2-Horse Power
- Manual Reset Motor Overload

##### Bowl Lift:

- Locks in any position

##### Bowl Stabilizer:

- Flat Exterior Bowl Base for Bowl Stability

##### Attachment Hub:

- Uses standard # 12 attachments

##### Timer:

- Automatic shutoff at desired mixing time

**Easy Maintenance and Service  
National Network of Service Professionals**

#### Safety features

##### Bowl Guard:

- Auto shut-off when bowl guard is opened.

##### Lift Safety:

- Auto shut-off when bowl is lowered.

Speed	Agitator RPMs	Attachment Hub RPM's
1	104	119
2	197	226
3	331	380

Specifications are subject to change.

**Precision North America, LLC.**  
60 Commerce Ave.  
Albany, New York 12206

www.precisionmixers.com • Phone: 1-877-R-MIXERS (1-877-764-9377) • Fax: 518-462-3389





**Standard Equipment and Features**

- » 4 - Horse Power Motor
- » 208/240 Volt
- » Single or 3-Phase
- » Gear-Reduction Transmission
- » 30-Minute Timer with automatic shut-off
- » 3-Speed
- » #12 Attachment Hub
- » Stainless Steel Bowl Guard
- » Bowl Lift Safety
- » Manual Bowl Lift
- » Dough Hook
- » Wire Whip
- » Beater/Paddle
- » Stainless Steel Bowl
- » Bowl Locking Handles
- » Bowl Stabilizer
- » Bowl Dolly, for easy transportation of mixed product
- » **Industry Leading, 3-Year Limited Parts Warranty**
- » **1-Year Full Parts and Labor Warranty**

**Optional Accessories**

- » 80-quart Pastry Knife
- » 40-quart Knockdown Plate
- » 40-quart Bowl
- » 40-quart Pastry Knife
- » Whip, Beater, and Hook for 40-quart Bowl
- » Whip, Beater, and Hook for 60-quart Bowl
- » 60-quart knockdown bowl

**Please specify when ordering mixer.**



**Built to Last . . .  
Priced to Save!**

**Precision North America, LLC.  
60 Commerce Ave.  
Albany, New York 12206**

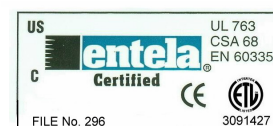

**www.precisionmixers.com • Phone: 1-877-R-MIXERS (1-877-764-9377) • Fax: 518-462-3389**



### Specifications and Dimensions

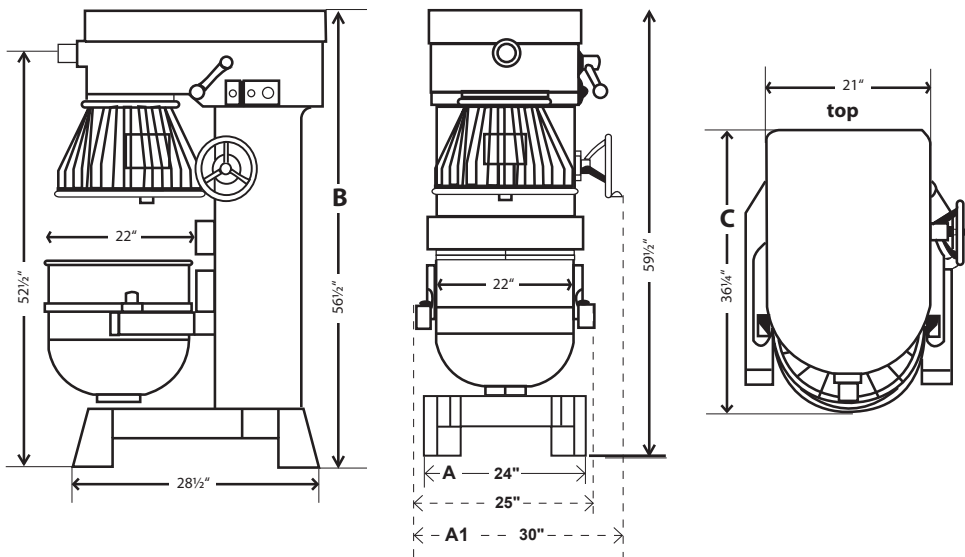

#### Electrical:

- 208/240 Volt
- 1 or 3-Phase Power
- Entela Approved

#### Weight:

- 880 Pounds Net
- 1005 Domestic Shipping

#### Warranty:

- 3-Year Limited Parts, (Motor, Transmission, and Drive-Train)
- 1-Full Year Parts and Labor

#### Amp Draw Specifications

Phase	Volts	Amps
1	208	16.1
3	240	14

#### Dimensions

##### Mixer Body:

- A: 24" Wide A1: 30" Wide
- B: 59 1/2" High
- C: 37" Depth

##### Bowl:

- Outside w/handles: 25"
- Inside: 19 3/4"
- Height: 19 3/4"

**NOTE:** Hub attachment not to be used while mixing

#### Benefits

##### Motor:

- Heavy Duty, 4-Horse Power
- Manual Reset Motor Overload

##### Bowl Lift:

- Locks in any position

##### Bowl Stabilizer:

- Flat Exterior Bowl Base for Bowl Stability

##### Attachment Hub:

- Uses standard # 12 attachments

##### Timer:

- Automatic shutoff at desired mixing time

**Easy Maintenance and Service  
National Network of Service  
Professionals**

#### Safety features

##### Bowl Guard:

- Auto shut-off when bowl guard is opened.

##### Lift Safety:

- Auto shut-off when bowl is lowered.

Speed	Agitator RPMs	Attachment Hub RPM's
1	104	119
2	197	226
3	331	380

Specifications are subject to change.

**Precision North America, LLC.**  
60 Commerce Ave.  
Albany, New York 12206

**www.precisionmixers.com • Phone: 1-877-R-MIXERS (1-877-764-9377) • Fax: 518-462-3389**





**Precision  
Mixers**

## Precision 80-Quart Mixer

**Model V-80EL**

### Standard Equipment and Features

- » 4 - Horse Power Drive Motor 208/240 Volt
- » ¼ HP Lift Motor with gear reduction
- » 3-Phase
- » Gear-Reduction Transmission
- » 30-Minute Timer with automatic shut-off
- » 3-Speed
- » #12 Attachment Hub
- » Stainless Steel Bowl Guard
- » Bowl Lift Safety
- » Electric Bowl Lift
- » Dough Hook
- » Wire Whip
- » Beater/Paddle
- » Stainless Steel Bowl
- » Bowl Locking Handles
- » Bowl Stabilizer
- » Bowl Dolly, for easy transportation of mixed product
- » **Industry Leading, 3-Year Limited Parts Warranty**
- » **1-Year Full Parts and Labor Warranty**

### Optional Accessories

- » 80-quart Pastry Knife
- » 40-quart Knockdown Plate
- » 40-quart Bowl
- » 40-quart Pastry Knife
- » Whip, Beater, and Hook for 40-quart Bowl
- » Whip, Beater, and Hook for 60-quart Bowl
- » 60-quart knockdown bowl

**Please specify when ordering mixer.**



**Built to Last . . .  
Priced to Save!**

**Precision North America, LLC.  
60 Commerce Ave.  
Albany, New York 12206**



**www.precisionmixers.com • Phone: 1-877-R-MIXERS (1-877-764-9377) • Fax: 518-462-3389**



### Specifications and Dimensions

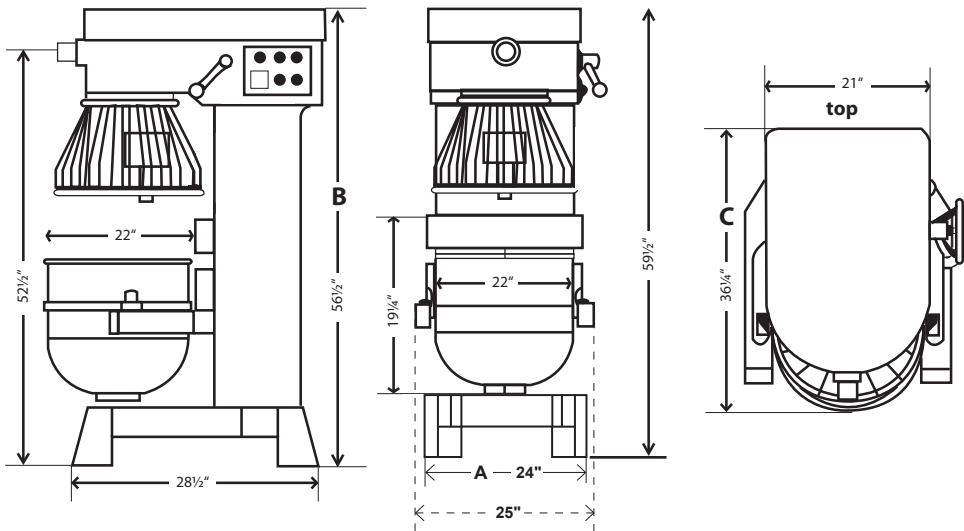

#### Electrical:

- 208/240 Volt
- 3-Phase Power
- Entela Approved

#### Weight:

- 910 Pounds Net
- 1035 Domestic Shipping

#### Warranty:

- 3-Year Limited Parts, (Motor, Transmission, and Drive-Train)
- 1-Full Year Parts and Labor

#### Amp Draw Specifications

Phase	Volts	Amps
3	240	14

#### Dimensions

##### Mixer Body:

- A: 24" Wide
- B: 59 1/2" High
- C: 37" Depth

##### Bowl:

- Outside w/handles: 25"
- Inside: 19 3/4"
- Height: 19 3/4"

**NOTE:** Hub attachment not to be used while mixing

#### Benefits

##### Motor:

- Heavy Duty, 4-Horse Power
- Manual Reset Motor Overload

##### Bowl Lift:

- Locks in any position

##### Bowl Stabilizer:

- Flat Exterior Bowl Base for Bowl Stability

##### Attachment Hub:

- Uses standard # 12 attachments

##### Timer:

- Automatic shutoff at desired mixing time

**Easy Maintenance and Service  
National Network of Service Professionals**

#### Safety features

##### Bowl Guard:

- Auto shut-off when bowl guard is opened.

##### Lift Safety:

- Auto shut-off when bowl is lowered.

Speed	Agitator RPMs	Attachment Hub RPM's
1	104	119
2	197	226
3	331	380

Specifications are subject to change.

**Precision North America, LLC.**  
60 Commerce Ave.  
Albany, New York 12206

www.precisionmixers.com • Phone: 1-877-R-MIXERS (1-877-764-9377) • Fax: 518-462-3389





**Precision  
Mixers**

**Precision 140-Quart Mixer**

**Model M140-W**

### Standard Equipment and Features

- » 6 - Horse Power Drive Motor 208/240 Volt
- » ½ HP Lift Motor with gear reduction
- » 3-Phase Power
- » Gear-Reduction Transmission
- » 30-Minute Timer with automatic shut-off
- » 4-Speed
- » Stainless Steel Bowl Guard
- » Bowl Lift Safety
- » Electric Bowl Lift
- » Dough Hook
- » Wire Whip
- » Beater/Paddle
- » Stainless Steel Bowl
- » Bowl Locking Handles
- » Bowl Stabilizer
- » Bowl Dolly, for easy transportation of mixed product
- » **Industry Leading, 3-Year Limited Parts Warranty**
- » **1-Year Full Parts and Labor Warranty**



### Optional Accessories

- » 80-quart Knockdown Plate
- » 80-quart Bowl
- » Whip, Beater, and Hook for 80-quart Bowl
- » Pastry Knife
- » Heavy Duty Whip

**Please specify when ordering mixer.**

**Built to Last . . .  
Priced to Save!**

**Precision North America, LLC.  
60 Commerce Ave.  
Albany, New York 12206**



**www.precisionmixers.com • Phone: 1-877-R-MIXERS (1-877-764-9377) • Fax: 518-462-3389**



### Specifications and Dimensions

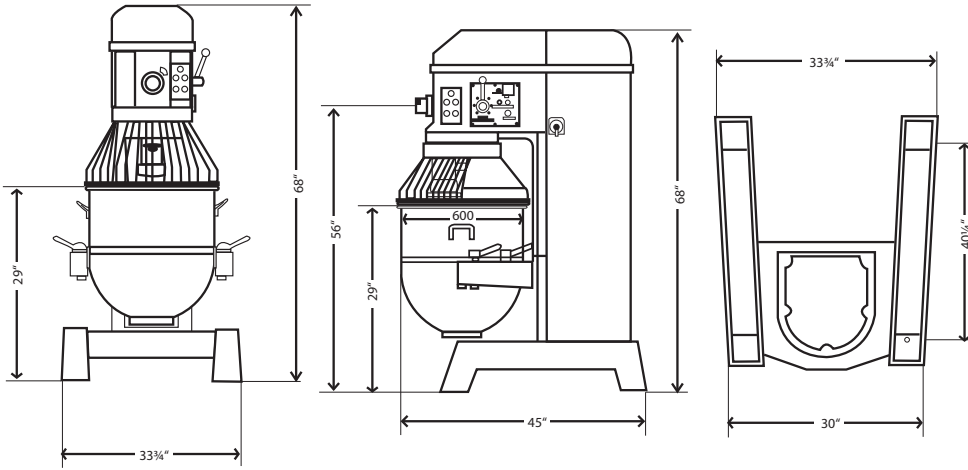

#### Electrical:

- 208/240 Volt
- 3-Phase Power
- Entela Approved

#### Weight:

- 2204 Pounds Net
- 2645 Domestic Shipping

#### Warranty:

- 3-Year Limited Parts, (Motor, Transmission, and Drive-Train)
- 1-Full Year Parts and Labor

#### Amp Draw Specifications

Phase	Volts	Amps
3	240	16.3

#### Dimensions

##### Mixer Body:

- A: 33 3/4" Wide
- B: 68" High
- C: 45 1/2" Depth

##### Bowl:

- Outside w/handles: 28"
- Inside: 23"
- Height: 24"

**NOTE:** Hub attachment not to be used while mixing

#### Benefits

##### Motor:

- Heavy Duty, 6-Horse Power
- 1/2 HP lift Motor independent from Drive Motor
- Manual Reset Motor Overload

##### Bowl Lift:

- Locks in any position

##### Bowl Stabilizer:

- Flat Exterior Bowl Base for Bowl Stability

##### Timer:

- Automatic shutoff at desired mixing time

**Easy Maintenance and Service National Network of Service Professionals**

#### Safety features

##### Bowl Guard:

- Auto shut-off when bowl guard is opened.

##### Lift Safety:

- Auto shut-off when bowl is lowered.

Speed	Agitator RPMs
1	55
2	92
3	163
4	288

Specifications are subject to change.

**Precision North America, LLC.**  
**60 Commerce Ave.**  
**Albany, New York 12206**

**www.precisionmixers.com • Phone: 1-877-R-MIXERS (1-877-764-9377) • Fax: 518-462-3389**







## Standard Equipment and Features

- » 70 Liter Stainless Steel Mixing Bowl
- » 55 lbs. of flour
- » 88 lbs. of dough
- » Bowl dimensions 21" x 14"
- » 2 speeds Spiral and Bowl drive
- » 2 timers to program the working cycle
- » Stainless Steel Security Guard & Spiral Hook
- » Bowl motor: 3.5 HP
- » Electricity: 208/230V / 3 phase
- » NET Weight 827 lbs.
- » Dimensions 39" x 23" x 42.5"
- » **Industry Leading, 3-Year Limited Parts Warranty**
- » **1-Year Full Parts and Labor Warranty**



## Features

- » Handles heavier PIZZA & BAGEL dough at LOW speed only
- » Reversible mixing action makes better dough, and in less time
- » Heavy-duty construction and powerful two-motor system
- » Heat treated enamel coating resists scratches, rust, and dents
- » Mounted on castors for extra mobility
- » Overload relay protects motor and transmission
- » Emergency Stop for safety operation

**Precision North America, LLC.**  
**60 Commerce Ave.**  
**Albany, New York 12206**

Model	Flour	Dough	Power	Bowl Dim.	Dimension	NET Weight
S-80	55 lbs.	88 lbs.	3.5 HP	21" x 14"	39" x 23" x 42.5"	827 lbs.
S-100	84 lbs.	132 lbs.	4.75 HP	23.6" x 13.9"	43" x 25.6" x 42.5"	870 lbs.
S-150	110 lbs.	176 lbs.	6.75 HP	26.3" x 15.7"	48" x 28.3" x 46.8"	992 lbs.

**www.precisionmixers.com • Phone: 1-877-R-MIXERS (1-877-764-9377) • Fax: 518-462-3389**



### Standard Equipment and Features

- » 100 Liter Stainless Steel Mixing Bowl
- » 84 lbs. of flour
- » 132 lbs. of dough
- » Bowl dimensions 23.6" x 13.9"
- » 2 speeds Spiral and Bowl drive
- » 2 timers to program the working cycle
- » Stainless Steel Security Guard & Spiral Hook
- » Bowl motor: 4.75 HP
- » Electricity: 208/230V / 3 phase
- » NET Weight 870 lbs.
- » Dimensions 43" x 25.6" x 42.5"
- » **Industry Leading, 3-Year Limited Parts Warranty**
- » **1-Year Full Parts and Labor Warranty**



### Features

- » Handles heavier PIZZA & BAGEL dough at LOW speed only
- » Reversible mixing action makes better dough, and in less time
- » Heavy-duty construction and powerful two-motor system
- » Heat treated enamel coating resists scratches, rust, and dents
- » Mounted on castors for extra mobility
- » Overload relay protects motor and transmission
- » Emergency Stop for safety operation

**Precision North America, LLC.**  
60 Commerce Ave.  
Albany, New York 12206

Model	Flour	Dough	Power	Bowl Dim.	Dimension	NET Weight
S-80	55 lbs.	88 lbs.	3.5 HP	21" x 14"	39" x 23" x 42.5"	827 lbs.
S-100	84 lbs.	132 lbs.	4.75 HP	23.6" x 13.9"	43" x 25.6" x 42.5"	870 lbs.
S-150	110 lbs.	176 lbs.	6.75 HP	26.3" x 15.7"	48" x 28.3" x 46.8"	992 lbs.



### Standard Equipment and Features

- » 130 Liter Stainless Steel Mixing Bowl
- » 110 Lbs. of flour
- » 176 Lbs. of dough
- » Bowl dimensions 26.3" x 15.7"
- » 2 speeds Spiral and Bowl drive
- » 2 timers to program the working cycle
- » Stainless Steel Security Guard & Spiral Hook
- » Bowl motor: 6.75 HP
- » Electricity: 208/230V / 3 phase
- » N.W. 992 lbs.
- » Dim. 48" x 28.3" x 46.8"
- » **Industry Leading, 3-Year Limited Parts Warranty**
- » **1-Year Full Parts and Labor Warranty**



### Features

- » Handles heavier PIZZA & BAGEL dough at LOW speed only
- » Reversible mixing action makes better dough, and in less time
- » Heavy-duty construction and powerful two-motor system
- » Heat treated enamel coating resists scratches, rust, and dents
- » Mounted on castors for extra mobility
- » Overload relay protects motor and transmission
- » Emergency Stop for safety operation

**Precision North America, LLC.**  
60 Commerce Ave.  
Albany, New York 12206

Model	Flour	Dough	Power	Bowl Dim.	Dimension	NET Weight
S-80	55 lbs.	88 lbs.	3.5 HP	21" x 14"	39" x 23" x 42.5"	827 lbs.
S-100	84 lbs.	132 lbs.	4.75 HP	23.6" x 13.9"	43" x 25.6" x 42.5"	870 lbs.
S-150	110 lbs.	176 lbs.	6.75 HP	26.3" x 15.7"	48" x 28.3" x 46.8"	992 lbs.

**www.precisionmixers.com • Phone: 1-877-R-MIXERS (1-877-764-9377) • Fax: 518-462-3389**



## Standard Equipment and Features

- » 200 Liter Stainless Steel Mixing Bowl
- » 165 Lbs. of flour
- » 264.5 Lbs. of dough
- » Bowl dimensions 29.5" x 17.7"
- » 2 speeds Spiral and Bowl drive
- » 2 timers to program the working cycle
- » Stainless Steel Security Guard & Spiral Hook
- » Bowl motor: 7.5 & .75 HP
- » Electricity: 208/230V / 3 phase
- » N.W. 1102 lbs.
- » Dim. 50" x 28" x 47"
- » **Industry Leading, 3-Year Limited Parts Warranty**
- » **1-Year Full Parts and Labor Warranty**



## Features

- » Handles heavier PIZZA & BAGEL dough at LOW speed only
- » Reversible mixing action makes better dough, and in less time
- » Heavy-duty construction and powerful two-motor system
- » Heat treated enamel coating resists scratches, rust and dents
- » Mounted on castors for extra mobility
- » Overload relay protects motor and transmission
- » Emergency Stop for safety operation

**Precision North America, LLC.  
60 Commerce Ave.  
Albany, New York 12206**

Model	Flour	Dough	Power	Bowl Dim.	Dimension	NET Weight
S-200	165 lbs.	264 lbs.	7.5 & 3/4 HP	29.5" x 17.7"	50" x 28" x 47"	1102 lbs.
S-200B	165 lbs.	264 lbs.	10 & 2 HP	33.5" x 17.7"	55" x 34.6" x 53"	870 lbs.

**www.precisionmixers.com • Phone: 1-877-R-MIXERS (1-877-764-9377) • Fax: 518-462-3389**



## Standard Equipment and Features

- » 24" Diameter bowl with moulding surface
- » Adjustable kneading stroke length
- » Hand feed or use under a divider
- » Sealed heavy duty ball bearings
- » Easy to clean removable bowl
- » Top in cast, anodized aluminum
- » Anti-adhesive process moulding surface
- » **1-Year Full Parts and Labor Warranty on site**



## 5-Year Labor Warranty

Precision will provide the labor to repair your rounder free of charge in years 2 through 5 at our facility, 60 commerce Ave., Albany NY 12816. Customer will be responsible for shipping both ways. Parts not included.

## Dimensions and Capacity

- » **Moulding bowl** — 24" diameter bowl
- » **Capacity** — 1 oz. to 24 oz.
- » **Output** — 400-700 pcs / hour
- » **Motor Power** — Powerful 1/2 HP motor
- » **Voltage** — 115 V \*Must be on a dedicated Circuit\*
- » **Net Weight** — 115 lbs.
- » **Dimensions** — 29" x 26" x 20"

**Precision North America, LLC.**  
**60 Commerce Ave.**  
**Albany, New York 12206**



## Standard Equipment and Features

- » All-In-Front ergonomic designs saves space
- » Four High Performance Nonstic Rollers with a rolling Width of 20" and sheet thickness of 0.04"-0.08"
- » Small footprint can be suitable for countertops and includes rubber feet to stay in place.
- » Push button control offers one-touch convenience
- » Adjustable handle controls output thickness with easy turn
- » Overload protection & Safety device conform to Health standard
- » Power white paint and heat treated to resist rust, scratches, and dents
- » 1-Year Full Parts and Labor Warranty
- » ETL Certification



## Dimensions and Capacity

- » **Base - 2" Adjustable Horizontal Level Foot Pad**
- » **Output** — 400-700 pcs / hour
- » **Motor Power** — Powerful 1 1/2 HP motor
- » **Voltage** — 115 V \* **Must be Used on a Dedicated Circuit\***
- » **Net Weight** — 298 lbs.
- » **Dimensions** — 37" x 28" x 37"



**Precision North America, LLC.**  
**60 Commerce Ave.**  
**Albany, New York 12206**

- **The Lowest Maintenance**
- **The Longest Warranty**
- **The Lowest Cost of Ownership**



**Precision North America, LLC.**  
**60 Commerce Ave.**  
**Albany, New York 12206**

**[www.precisionmixers.com](http://www.precisionmixers.com)**

**Phone: 1-877-R-MIXERS (1-877-764-9377) • Fax: 518-462-3389**